

# PATTERN DETAIL MEASUREMENTS

NOTE: MEASUREMENTS ARE APPROXIMATE AND WILL VARY WITH REGISTER SIZE.

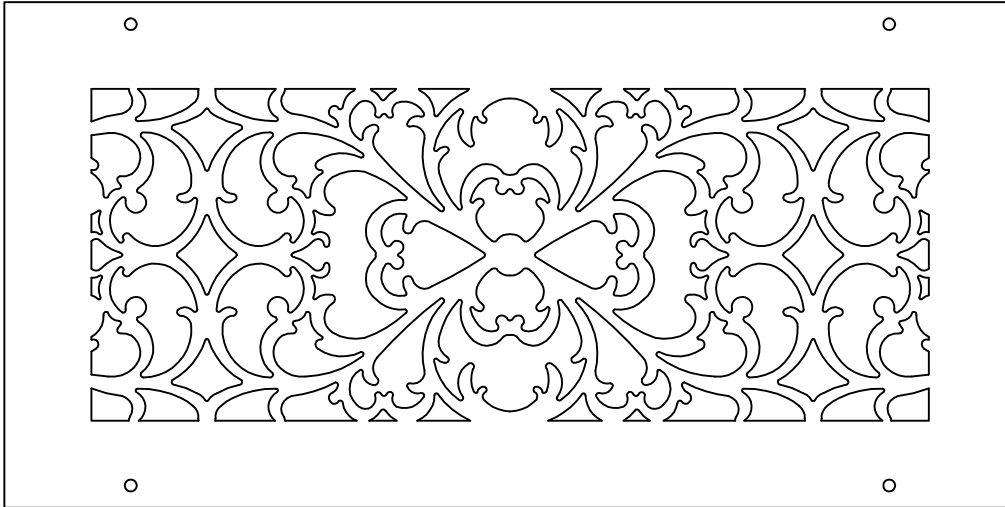
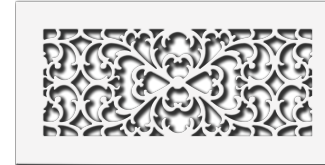
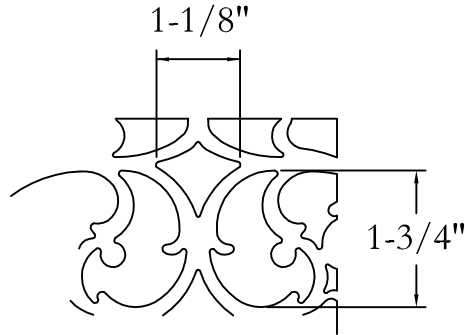

## CHARLESTON DESIGN AIR FLOW / PERFORMANCE DATA

	250	500	750	1000	1500
Velocity	250	500	750	1000	1500
Static Pressure	0.02	0.042	0.063	0.084	0.126
SIZE	CUBIC FEET PER MINUTE (CFM)				
6x6 (.25ft <sup>2</sup> )	38	75	115	155	230
8x8 (.44ft <sup>2</sup> )	68	135	205	270	405
10x10 (.69ft <sup>2</sup> )	105	210	315	425	635
12x12 (1.0ft <sup>2</sup> )	155	305	460	610	915
14x14 (1.36ft <sup>2</sup> )	211	415	626	830	1245
8x6 (.33ft <sup>2</sup> )	52	102	153	203	305
10x6 (.42ft <sup>2</sup> )	65	127	192	254	381
12x6 (.5ft <sup>2</sup> )	77	152	230	305	457
14x6 (.58ft <sup>2</sup> )	90	178	268	356	534
16x6 (.67ft <sup>2</sup> )	103	203	307	407	610
18x6 (.75ft <sup>2</sup> )	116	229	345	457	686
20x6 (.83ft <sup>2</sup> )	129	254	383	508	762
10x8 (.56ft <sup>2</sup> )	86	169	256	339	508
12x8 (.67ft <sup>2</sup> )	103	203	307	407	610
14x8 (.78ft <sup>2</sup> )	121	237	358	474	712
8x4 (.22ft <sup>2</sup> )	34	68	102	136	203
10x4 (.28ft <sup>2</sup> )	43	85	128	169	254
12x4 (.33ft <sup>2</sup> )	52	102	153	203	305



MATERIAL: 11 GAUGE STEEL  
 ABOVE DIMENSIONS ARE IN INCHES  
 FINISH: TO BE DETERMINED

PATTERN OPENNESS: 65%

SCALE	NONE
DRAWN	DH
DATE	10-18-06
Q.A.	

COMMENTS

## CHARLESTON DESIGN

THIS INFORMATION CONTAINED IN THIS DRAWING IS THE SOLE PROPERTY OF STEELCREST CORPORATION. ANY REPRODUCTION IN PART OR AS A WHOLE WITHOUT WRITTEN PERMISSION OF STEELCREST CORPORATION IS PROHIBITED